

MULTIEDGE

Range w.t. 6 - 60 mm (2/8" - 2 3/8")

Macchina compatta e versatile, dalle poliedriche funzionalità, quali splaccatura, intestatura e smussatura di lamiere.

Compact and versatile machine with a wide functions range such as cladding removal, facing and bevelling of plates.

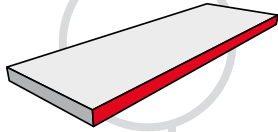

1

intestatura - facing

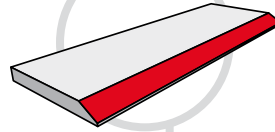
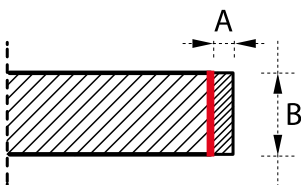

2

smussatura - bevelling

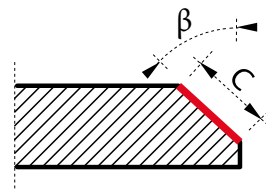

Nel rispetto dei più elevati standard di sicurezza, garantisce la salvaguardia dell'operatore grazie al sensore di rilevazione presenza lamiera. La fresa ad alta velocità può ospitare 8 o 9 inserti intercambiabili, a seconda dell'utilizzo, disponibili per qualsiasi tipologia di materiale.

Complying with the highest safety standards, this machine guarantees the safeguard of the operator with a plate detecting sensor. The high speed face mill can host 8 to 9 interchangeable inserts depending by the application of the case, available for any material typology.

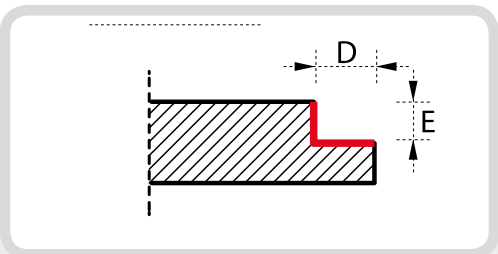

- Macchina compatta e versatile;
- Possibilità di: splaccare, intestare e smussare lamiere;
- Elevati standard di sicurezza grazie al sensore presenza lamiera;
- Fresa ad alta velocità con inserti;
- Diversi tipi di inserti;
- Carrellino integrato;
- Innovativo sistema di trascinamento;
- Doppio sistema di ammortizzazione.

- Compact and versatile machine;
- Diversified functions : clad removal, facing and bevelling;
- High safety standards guaranteed by the plate detecting sensor;
- High speed face mills with interchangeable inserts;
- Different type of inserts available;
- Integrated trolley;
- Innovative feeding system;
- Dual amortization system.

1	INTESTATURA - FACING	
	A	B
	1 mm (each step)	Max 45 mm

2	SMUSSO - BEVELLING	
	β	C
	Min 15°	40 mm
	Max 80°	

3	SPLACCATURA - CLAD REMOVAL	
	D	E
	Min 10mm	Max 10 mm
	Max 50mm	

MULTIEDGE

Range w.t. 6 - 60 mm (2/8" - 2 3/8")

L'innovativo sistema di trascinamento offre non solo ingombri ridotti ma qualità di trasmissione superiore.
Peculiarità del carrello integrato, dotato di dispositivo convogliamento truciolo, è il doppio sistema di ammortizzazione per rendere più scorrevole la lavorazione e ovviare a eventuali imperfezioni.

*The innovative feeding system offers not only a limited encumbrance but also a superior transmission quality.
Peculiarity of the integrated trolley, equipped with a chips collecting tray, is the dual amortization system designed to deliver a smooth working phase and to compensate eventual imperfections both of the plate and the ground.*



TESTA INCLINABILE
ROTATING HEAD



DIMENSIONI - DIMENSIONS

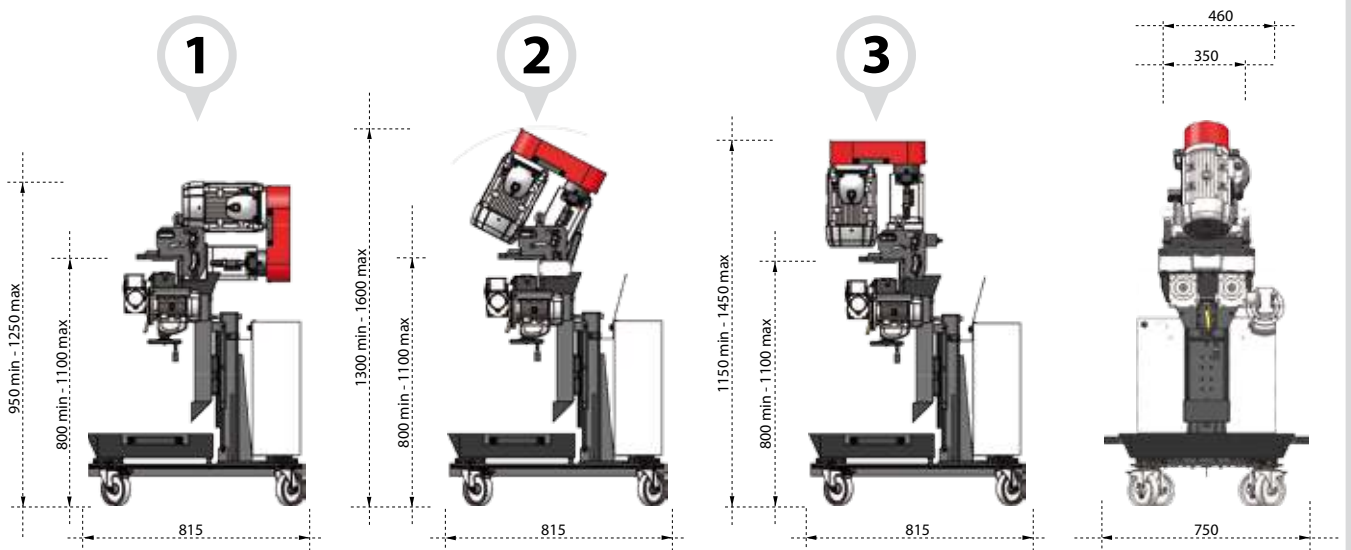



Regolatore di Velocità a bordo macchina *Onboard Speed Regulator*

Completamente integrato nel quadro comandi, il variatore di velocità ci permette di lavorare con ottimi risultati in termini di qualità e di produttività le diverse tipologie di materiali, anche le più tenaci.

Fully integrated with the control panel, the speed regulator enables the operator to obtain excellent results in terms of quality and productivity on the several steel typologies, even the hardest.

Intuitivo e estremamente facile nell'utilizzo tramite il display digitale, il nuovo dispositivo consente di variare la velocità della fresa da 300 g/min a 800 g/min.

Intuitive and extremely user friendly thanks to the digital display, this new device enables to adjust the face mill rotation speed from 300 rpm up to 800 rpm.

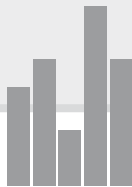

I parametri possono essere impostati prima della lavorazione, se si conoscono le caratteristiche del materiale, oppure variati in corso d'opera al fine di individuare la regolazione ottimale.

The parameters can either be set prior to the operations, when the material specifications are known, or they can be set during the operations in order to assess the optimal speed rate.



MULTIEDGE le frese - *the face mills*

L'unità può essere equipaggiata con 3 diverse tipologie di fresa, in base alla finitura dello smusso da eseguire:

Fresa A:

- Smussatura;
- Intestatura;
- Splaccatura con finitura a 45°

Fresa B:

- Splaccatura con finitura a 90°

Fresa C:

- Splaccatura con finitura a J

The unit can be equipped with 3 different typologies of face mills in accordance with the bevel to be executed.

Face mill A:

- *Beveling*
- *Facing*
- *Cladding Removal with 45° finishing*

Face mill B:

- *Cladding Removal with 90° finishing*

Face mill C:

- *Cladding Removal with "J" finishing*

A

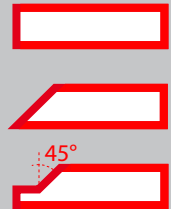

B



C



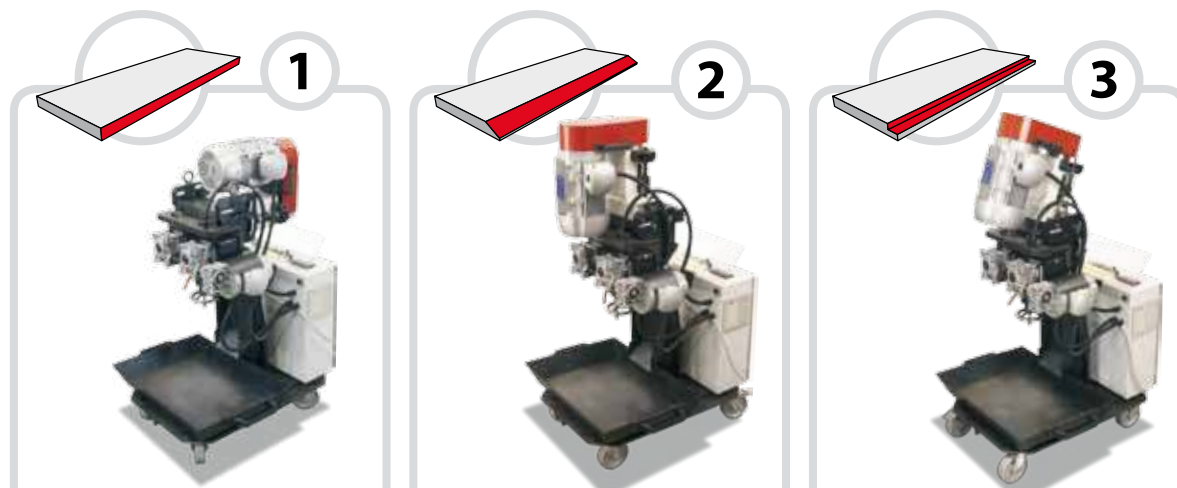

DATI TECNICI - TECHNICAL FEATURES

potenza motore elettrico <i>electric motor power</i>	Kw	3
alimentazione std. <i>std. voltage</i>	volt/Hz/phase	400/50/3
n° giri fresa <i>face mill RPM</i>	gg/min	min 300 - max 800
fresa smusso (Ø) a 9 inserti <i>9 Inserts face mill for bevel (Ø)</i>	mm	80
fresa per splaccatura (Ø) a 8 inserti <i>8 Inserts face mill for clad removal (Ø)</i>	mm	80
angolo di smusso <i>beveling angle</i>		15° ÷ 80°
larghezza di splaccatura <i>clad removal width</i>	mm	min 10 - max 50
profondità di splaccatura <i>clad removal depth</i>	mm	min 10 - max 50
spessore max intestatura lamiera <i>max facing thickness</i>	mm	max 45
spessore della lamiera <i>plate thickness</i>	mm	min 6 - max 60
lunghezza smusso (diagonale) <i>bevel length (diagonal)</i>	mm	max 40
velocità di avanzamento <i>feeding speed rate</i>	mt/min	0 ÷ 1.6
peso totale macchina <i>weight</i>	kg	205
peso testa senza carrello <i>head weight without trolley</i>	kg	138
peso carrellino <i>trolley weight</i>	kg	67
emissione acustica max a vuoto <i>max acoustic emissions in Idle</i>	db	76
emissione acustica media sotto sforzo <i>media max acoustic emissions in Idle</i>	db	86

*Differenti voltaggi a richiesta - **different voltage available on request*